

General set up

- 1 Mount the fixture in the required position. The integral yoke can act as a floor stand or hanger.

Important

- When suspending the fixture, use at least two clamps onto the front or rear (or both) of the PixelMax Wash yoke.
- When suspending the fixture, always use a safety wire rated to a minimum of 64kg (140lbs) around the yoke. Threaded M8 bushes in the side panels also allow the use of load eyes.
- Do not position the fixture close to fog machines. The fog oil mist will be drawn in by the cooling fans and will short out important components. The warranty will be void for all fixtures returned in such a condition.

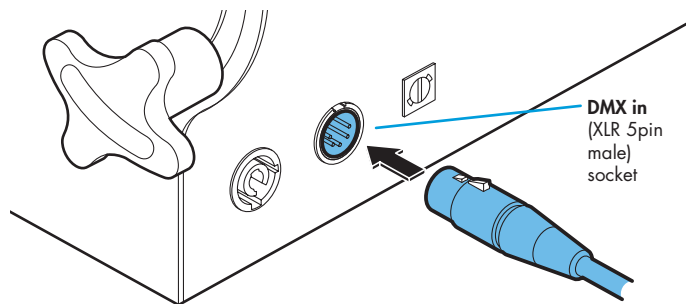

- 2 Where external control is to be used, connect a DMX lead (XLR 5-pin female) to the input socket at the rear of the fixture.
- 3 Where other fixtures are to be used in a control daisy-chain, connect a DMX lead (XLR 5-pin male) to the output socket at the rear of the fixture. Where a power daisy-chain is also required, use the white Neutrik PowerCon output socket (see warning below).

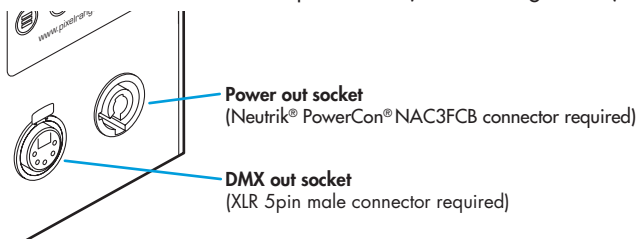

- 4 Connect power to the fixture using a Neutrik PowerCon connector. Insert the connector and twist it clockwise until it clicks into place.

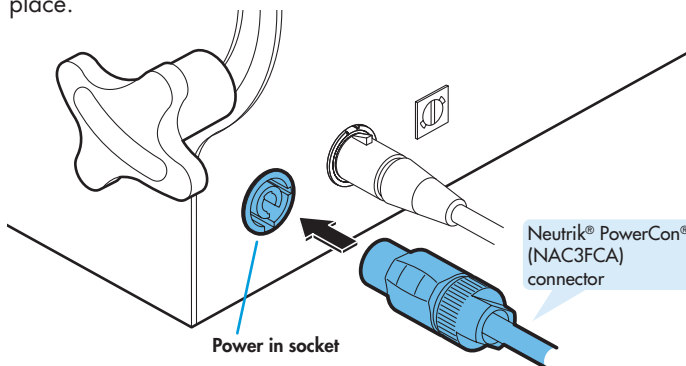

Important

- When daisy-chaining fixtures, do not exceed a total load of 3kW in a single daisy chain (subject to supply and cabling restrictions). Maximum power requirement per fixture: 320 watts. See also the 'Start up (peak)' note on page 6.

- 5 Use the control panel to access the internal menu and choose the appropriate operation mode and related settings (see over).

Beam spreading

The upper and lower cell panels can be tilted independently to make their beams diverge from the centre by up to 16 degrees.

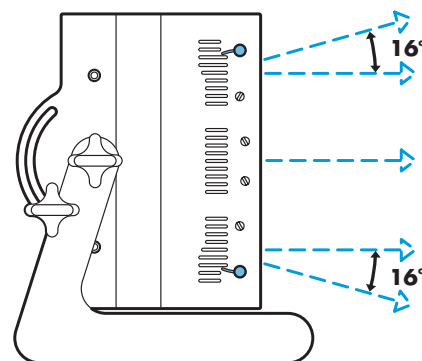

To spread a beam

Loosen the adjustment screws at either side of the cell panel. Use the knobs to tilt the panel to the required angle and then tighten.

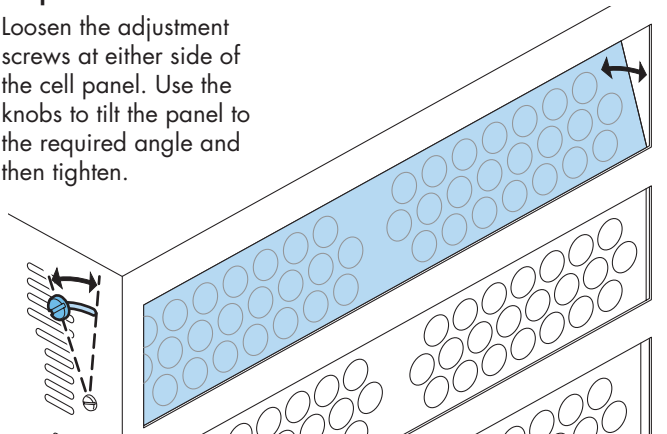

Operation modes

The PixelMax Wash provides a range of operation modes. These are selected using the **Mode** section of the control menu:

- DMX** Allows RGB(A) control via DMX input. Using the **RES** (resolution) option you can determine the number of DMX channels required: between 3 and 24. Internal chase effects are not available within this mode.
- MANU** Provides RGBA colour mixing independently of any external control. Use the internal control menu (**MANU** section) to select the required colour values.
- EF M** Allows the display of the dual internal chase effects, independently of any external control. Use the internal control menu (**PROP** section) to select the required chase effects, speeds and cross fades.
- 24+E** Provides control of RGBA mixing and selection of the dual internal chase effects via DMX input. Requires 31 DMX channels.
- 4+E** Provides control of RGBA mixing and selection of the dual internal chase effects via DMX input. Requires 11 DMX channels.
- 16bT** Allows RGB(A) control via DMX input, using two 8bit channels per colour. The **RES** and **MINT** options determine how many channels are required. Internal chase effects are not available within this mode.

Note

- To optionally clear all previous settings: At the rear panel, press the middle two buttons (▲ and ▼) while the current address and mode are being scrolled across the display. The four digit display will show **0000** then **RESET** to indicate that the fixture has been returned to its default condition.

Menu operation

General notes

- Ensure that only one DMX device in the chain is set as master (e.g. the lighting desk). This fixture is usually set to slave mode.
- This fixture is shipped with the DMX address set to 001.
- The four digit display can be set to switch off when not in use. To restore, press **MENU**. To alter this mode use: **PERS > DISP**.



Using the menu

- When not in the menu, the four digit display scrolls the current DMX address and mode. The display's right hand decimal point (data dot) is used to indicate status (see below).
- Press **MENU** to enter the menu. The four digit display will show **Addr**.
- Use **DOWN** and **UP** to move between menu options (or to change a value within an option).
- Press **ENTER** to enter an option (or to fix a changed value within an option and return to the previous option level). *Note: If you do not press **ENTER** to fix a value, operation will revert to the previously set mode at the next power on.*
- Press **MENU** to exit from a menu option (and eventually exit the menu completely).

Chase effects

This section describes each of the 31 internal chase effects that are selectable either via the control menu (**PRG > C1/C2 > EFEC**) or using DMX values sent from an external source. To use the internal effects, set the **MODE** option either to **EF M** (to control effects via the menu) or **EF d / 4+E** (to control effects externally via DMX). See page 6 for details about controlling effects on other fixtures via DMX without using a control desk.

DMX value	EFEC value	Chase effect description
0-7	00	Off
8-15	01	Rainbow chase forward (cells A > F)
16-23	02	Rainbow chase reverse (cells F > A)
24-31	03	White chase forward (cells A > F)
32-39	04	White chase reverse (cells F > A)
40-47	05	White chase in cell pairs (cells A, F > B, E > C, D)
48-55	06	50/50 duty cycle strobe white (all cells)
56-63	07	50/50 duty cycle strobe red (all cells)
64-71	08	50/50 duty cycle strobe blue (all cells)
72-79	09	50/50 duty cycle strobe yellow (all cells)
80-87	10	50/50 duty cycle strobe green (all cells)
88-95	11	Pulse strobe white (all cells)
96-103	12	Pulse strobe blue (all cells)
104-111	13	Pulse strobe rainbow (all cells)
112-119	14	Pulse strobe red/green/blue (all cells)
120-127	15	Primary/secondary chase (all cells)
128-135	16	Red/green/blue chase (all cells)
136-143	17	Alternate yellow/blue (all cells)
144-151	18	Rainbow chase (cells A, B, C > D, E, F)
152-159	19	Yellow/blue chase (cells A, C, E > B, D, F)
160-167	20	Red/blue chase (cells A, C, E > B, D, F)
168-175	21	Red/yellow chase (cells A, B, E, F > C, B)
176-183	22	Red/green/blue chase (cells A, B > C, D > E, F)
184-191	23	Red/green/blue chase (cells A, B > C, D > E, F)
192-199	24	Red/green/blue chase (cells E, F > C, D > A, B)
200-207	25	Static orange (all cells)
208-215	26	Static yellow (all cells)
216-223	27	Static light blue (all cells)
224-231	28	Static purple (all cells)
232-239	29	Static red (all cells)
240-247	30	Static green (all cells)
248-255	31	Random colour chase (individual cells)

Master/slave/data indication

The right hand decimal point (data dot) of the display is used to indicate the master/slave settings and also the presence of a DMX input signal, as shown below:



Data dot ON	Master mode
Data dot FLASHING	Slave mode (DMX data input present)
Data dot OFF	Slave mode (no DMX data present)

Notes:

- Ensure that only one DMX device in the chain is set as master (e.g. the desk).
- Use **PERS > dATR** to change between master & slave modes.
- When set to master mode, the fixture will scroll **MASTER** in place of a DMX address (when not within the menu).
- If the display has been set to auto off (**DISP > ROFF**), the data dot will remain active but at a lower brightness.

Dimming options (PERS > DIMR)

You have a choice of dimmer curve control options:

FINE is the standard setting and is fully compatible with the dimming curves of previous Pixel Range fixtures.

TUNG Alters the dimming response to closely emulate the very smooth action of standard tungsten bulbs.

Neutrik® PowerCon® (NAC3FCA) connector wiring

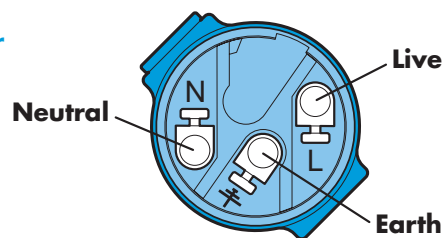

Menu contents

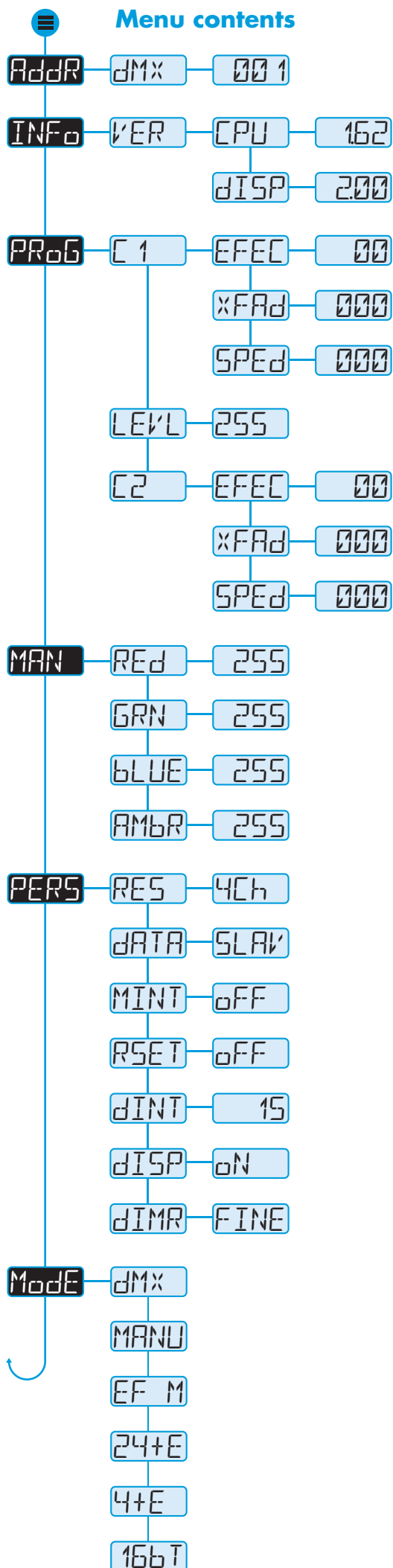

Sets the base DMX address from which the control channels will begin.

Shows the installed revision of the main fixture firmware. This is for information purposes only, no changes are possible within this option.

Shows the installed revision of the software used to control the four digit display panel. This is for information purposes only, no changes are possible within this option.

Selects the primary internal chase effect. See *Chase effects* for descriptions. Select *ModE* > *EF M* to show the selected chase.

Selects the cross fade speed between the steps of the selected *C 1* chase effect.

Selects the speed of the selected *C 1* chase effect.

Selects the master intensity level of chase effects *C 1* and *C2*.

Selects the secondary internal chase effect. See *Chase effects* for descriptions. Select *ModE* > *EF M* to show the selected chase.

Selects the cross fade speed between the steps of the selected *C2* chase effect.

Selects the speed of the selected *C2* chase effect.

Sets the red intensity. Select *ModE* > *MANU* (manual) to show the result.

Sets the green intensity. Select *ModE* > *MANU* (manual) to show the result.

Sets the blue intensity. Select *ModE* > *MANU* (manual) to show the result.

Sets the amber intensity. Select *ModE* > *MANU* (manual) to show the result.

(Affects *dM::* & *16bT* modes only) Determines how colours are assigned to DMX channels. Options are *24Ch/18Ch/12Ch/9Ch/8Ch/6Ch/4Ch* and *3Ch*.

Determines whether this fixture will act as a master controlling others. When controlled by DMX input, this fixture must be set to *SLAV*.

Affects *dM::* & *16bT* modes only. *GLobAL* enables a single master intensity. *CELL* enables a master intensity channel for each cell or group of cells.

When set *ON*, this option scrolls through the primary colours at power on to demonstrate correct operation.

Determines the intensity of the four digit control panel display. Values range from 0 (dimkest) to 15 (brightest).

When set to *FAFF*, the control panel display will blank out shortly after the menu is exited. The master/slave/DMX signal indication will remain active.

Allows you to choose dimming curve & response rate. *FINE* is compatible with previous Pixel Range fixtures. *TUNG* produces very smooth responses to DMX inputs.

8bit RGB(A) control using the number of DMX channels determined by *PERS* > *RES*. *PERS* > *MINT* determines master intensity channel(s). No chase effects are selectable.

Displays the resulting RGB levels that are set via the *MANU* section of the internal menu. When set as master, these levels are also output via DMX for the control of other fixtures.

Displays the chase effect(s) determined within the *PRoG* section. When set as master, these levels are also output via DMX for the control of other fixtures.

DMX Ch1 to 24: RGBA, Ch25 to 27: *C 1* Effect, Speed & Xfade, Ch28 to 30: *C2* Effect, Speed & Xfade, Ch31: Master intensity.

DMX Ch1 to 4: RGBA, Ch5 to 7: *C 1* Effect, Speed & Xfade, Ch8 to 10: *C2* Effect, Speed & Xfade, Ch11: Master intensity.

16bit RGB(A) control using 2x the number of DMX channels determined by *PERS* > *RES*. *PERS* > *MINT* determines master intensity channel(s). No chase effects are selectable.

Channel layouts within operation modes

These tables show how colour mixing, chase effects and master intensity controls are mapped to DMX channels for each mode that uses an external input. The **dm11** and **16bT** modes do not use chase effects. In all modes, the first channel of the fixture occurs at the DMX address selected using **AddrP** and successive channels for the fixture follow from there.

Notes:

The **PERS > RES** option determines the number of channels to use in **dm11** and **16bT** modes (**16bT** uses twice the number of channels setup within **RES**).

For **dm11** and **16bT** modes, the **PERS > MINT** option determines whether one or more master intensity channels should be used: **Off** = no master intensity, **Global** = one master intensity for the whole fixture, **Cell** = separate master intensity channels for each cell, or group of cells.

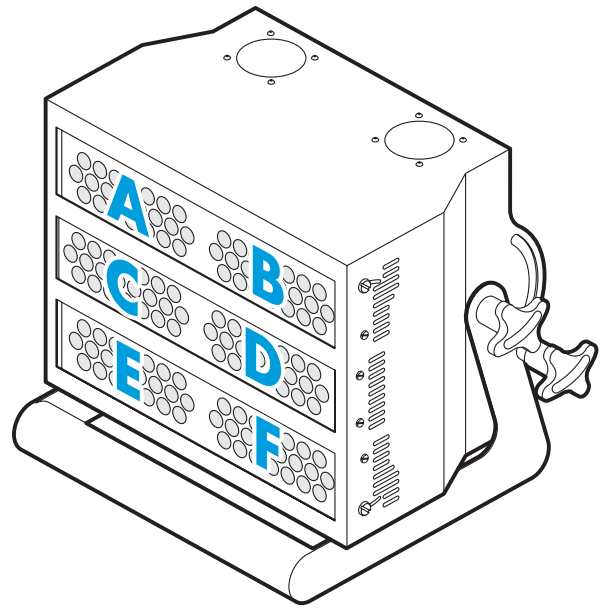

Mode = dm11

(**PERS > MINT** set to **OFF** or ***GLOBAL** to provide a single master intensity channel)

PERS > RES = 24Ch		PERS > RES = 18Ch		PERS > RES = 12Ch		PERS > RES = 9Ch		PERS > RES = 8Ch		PERS > RES = 6Ch		PERS > RES = 4Ch		PERS > RES = 3Ch	
Cells	R G B A	Cells	R+A G B	Cells	R G B A	Cells	R+A G B	Cells	R G B A	Cells	R+A G B	Cells	R G B A	Cells	R+A G B
A	1 2 3 4	A	1 2 3	A	1 2 3 4	A	1 2 3	A	1 2 3 4	A	1 2 3	A	1 2 3 4	A	1 2 3
B	5 6 7 8	B	4 5 6	B	5 6 7 8	B	4 5 6	B	5 6 7 8	B	4 5 6	B	1 2 3 4	B	1 2 3
C	9 10 11 12	C	7 8 9	C	9 10 11 12	C	7 8 9	C	1 2 3 4	C	1 2 3	C	1 2 3 4	C	1 2 3
D	13 14 15 16	D	10 11 12	D	13 14 15	D	10 11 12	D	5 6 7 8	D	4 5 6	D	1 2 3 4	D	1 2 3
E	17 18 19 20	E	13 14 15	E	17 18 19 20	E	13 14 15	E	1 2 3 4	E	1 2 3	E	1 2 3 4	E	1 2 3
F	21 22 23 24	F	16 17 18	F	21 22 23 24	F	16 17 18	F	5 6 7 8	F	4 5 6	F	1 2 3 4	F	1 2 3
Master intensity*	25	Master intensity*	19	Master intensity*	13	Master intensity*	10	Master intensity*	9	Master intensity*	7	Master intensity*	5	Master intensity*	4

Mode = dm11

(**PERS > MINT** set to **CELL** to provide master intensity channels for each cell or group of cells)

PERS > RES = 24Ch		PERS > RES = 18Ch		PERS > RES = 12Ch		PERS > RES = 9Ch		PERS > RES = 8Ch		PERS > RES = 6Ch		PERS > RES = 4Ch		PERS > RES = 3Ch	
Cells	R G B A Int	Cells	R+A G B Int	Cells	R G B A Int	Cells	R+A G B Int	Cells	R G B A Int	Cells	R+A G B Int	Cells	R G B A Int	Cells	R+A G B Int
A	1 2 3 4 5	A	1 2 3 4	A	1 2 3 4 5	A	1 2 3 4	A	1 2 3 4 5	A	1 2 3 4	A	1 2 3 4 5	A	1 2 3 4
B	6 7 8 9 10	B	5 6 7 8	B	6 7 8 9 10	B	5 6 7 8	B	1 2 3 4 5	B	1 2 3 4	B	1 2 3 4 5	B	1 2 3 4
C	11 12 13 14 15	C	9 10 11 12	C	11 12 13 14 15	C	9 10 11 12	C	6 7 8 9 10	C	5 6 7 8	C	1 2 3 4 5	C	1 2 3 4
D	16 17 18 19 20	D	13 14 15 16	D	16 17 18 19 20	D	13 14 15 16	D	1 2 3 4 5	D	6 7 8 9 10	D	5 6 7 8	D	1 2 3 4
E	21 22 23 24 25	E	17 18 19 20	E	21 22 23 24 25	E	17 18 19 20	E	6 7 8 9 10	E	1 2 3 4 5	E	5 6 7 8	E	1 2 3 4
F	26 27 28 29 30	F	21 22 23 24	F	26 27 28 29 30	F	21 22 23 24	F	11 12 13 14 15	F	6 7 8 9 10	F	5 6 7 8	F	1 2 3 4

Mode = 24+E

This mode provides a combination of colour mixing and internal effects under the control of a DMX input.

See page 2 (Chase effects) for details of values for C1 and C2 effect channels.

ModE = 24+E	
Cells	R G B A
A	1 2 3 4
B	5 6 7 8
C	9 10 11 12
D	13 14 15 16
E	17 18 19 20
F	21 22 23 24
C1 effect	25
C1 speed	26
C1 xfade	27
C2 effect	28
C2 speed	29
C2 xfade	30
Master Int.	31

Mode = 4+E

This mode provides a combination of colour mixing and internal effects under the control of a DMX input.

See page 2 (Chase effects) for details of values for C1 and C2 effect channels.

ModE = 4+E	
Cells	R G B A
A	1 2 3 4
B	5 6 7 8
C	9 10 11 12
D	13 14 15 16
E	17 18 19 20
F	21 22 23 24
C1 effect	25
C1 speed	26
C1 xfade	27
C2 effect	28
C2 speed	29
C2 xfade	30
Master Int.	31

Mode = 16bT (16 bit)

(PERS > MINT set to OFF or *GLOBAL to provide a single master intensity channel)

In each pair of channels for a colour, the first channel provides the high (coarse) 8 bits while the second gives the low (fine) 8 bits

Cells		COARSE/FINE				PERS > RES =
						24Ch
		R	G	B	A	
A		1/2	3/4	5/6	7/8	
B		9/10	11/12	13/14	15/16	
C		17/18	19/20	21/22	23/24	
D		25/26	27/28	29/30	31/32	
E		33/34	35/36	37/38	39/40	
F		41/42	43/44	45/46	47/48	
						Master intensity* 49

Cells		COARSE/FINE			PERS > RES =
					18Ch
		R+A	G	B	
A		1/2	3/4	5/6	
B		7/8	9/10	11/12	
C		13/14	15/16	17/18	
D		19/20	21/22	23/24	
E		25/26	27/28	29/30	
F		31/32	33/34	35/36	
					Master intensity* 37

Cells		COARSE/FINE				PERS > RES =
						12Ch
		R	G	B	A	
A		1/2	3/4	5/6	7/8	
B		9/10	11/12	13/14	15/16	
C		17/18	19/20	21/22	23/24	
D		25/26	27/28	29/30	31/32	
E		33/34	35/36	37/38	39/40	
F		41/42	43/44	45/46	47/48	
						Master intensity* 25

Cells		COARSE/FINE			PERS > RES =
					9Ch
		R+A	G	B	
A		1/2	3/4	5/6	
B		7/8	9/10	11/12	
C		13/14	15/16	17/18	
D		19/20	21/22	23/24	
E		25/26	27/28	29/30	
F		31/32	33/34	35/36	
					Master intensity* 19

Cells		COARSE/FINE				PERS > RES =
						8Ch
		R	G	B	A	
A		1/2	3/4	5/6	7/8	
C		9/10	11/12	13/14	15/16	
E		17/18	19/20	21/22	23/24	
B		25/26	27/28	29/30	31/32	
D		33/34	35/36	37/38	39/40	
F		41/42	43/44	45/46	47/48	
						Master intensity* 17

Cells		COARSE/FINE			PERS > RES =
					6Ch
		R+A	G	B	
A		1/2	3/4	5/6	
C		7/8	9/10	11/12	
E		13/14	15/16	17/18	
B		19/20	21/22	23/24	
D		25/26	27/28	29/30	
F		31/32	33/34	35/36	
					Master intensity* 13

Cells		COARSE/FINE				PERS > RES =
						4Ch
		R	G	B	A	
A		1/2	3/4	5/6	7/8	
B		9/10	11/12	13/14	15/16	
C		17/18	19/20	21/22	23/24	
D		25/26	27/28	29/30	31/32	
E		33/34	35/36	37/38	39/40	
F		41/42	43/44	45/46	47/48	
						Master intensity* 9

Cells		COARSE/FINE			PERS > RES =
					3Ch
		R+A	G	B	
A		1/2	3/4	5/6	
B		7/8	9/10	11/12	
C		13/14	15/16	17/18	
D		19/20	21/22	23/24	
E		25/26	27/28	29/30	
F		31/32	33/34	35/36	
					Master intensity* 7

Mode = 16bT (16 bit)

(PERS > MINT set to CELL to provide master intensity channels for each cell or group of cells)

In each pair of channels for a colour, the first channel provides the high (coarse) 8 bits while the second gives the low (fine) 8 bits

Cells		COARSE/FINE					PERS > RES =
							24Ch
		R	G	B	A	Int	
A		1/2	3/4	5/6	7/8	9	
B		10/11	12/13	14/15	16/17	18	
C		19/20	21/22	23/24	25/26	27	
D		28/29	30/31	32/33	34/35	36	
E		37/38	39/40	41/42	43/44	45	
F		46/47	48/49	50/51	52/53	54	

Cells		COARSE/FINE				PERS > RES =
						18Ch
		R+A	G	B	Int	
A		1/2	3/4	5/6	7	
B		8/9	10/11	12/13	14	
C		15/16	17/18	19/20	21	
D		22/23	24/25	26/27	28	
E		29/30	31/32	33/34	35	
F		36/37	38/39	40/41	42	

Cells		COARSE/FINE					PERS > RES =
							12Ch
		R	G	B	A	Int	
A		1/2	3/4	5/6	7/8	9	
B		10/11	12/13	14/15	16/17	18	
C		19/20	21/22	23/24	25/26	27	
D		28/29	30/31	32/33	34/35	36	
E		37/38	39/40	41/42	43/44	45	
F		46/47	48/49	50/51	52/53	54	

Cells		COARSE/FINE				PERS > RES =
						9Ch
		R+A	G	B	Int	
A		1/2	3/4	5/6	7	
B		8/9	10/11	12/13	14	
C		15/16	17/18	19/20	21	
D		22/23	24/25	26/27	28	
E		29/30	31/32	33/34	35	
F		36/37	38/39	40/41	42	

Cells		COARSE/FINE					PERS > RES =
							8Ch
		R	G	B	A	Int	
A		1/2	3/4	5/6	7/8	9	
C		10/11	12/13	14/15	16/17	18	
E		19/20	21/22	23/24	25/26	27	
B		28/29	30/31	32/33	34/35	36	
D		37/38	39/40	41/42	43/44	45	
F		46/47	48/49	50/51	52/53	54	

Cells		COARSE/FINE				PERS > RES =
						6Ch
		R+A	G	B	Int	
A		1/2	3/4	5/6	7	
C		8/9	10/11	12/13	14	
E		15/16	17/18	19/20	21	
B		22/23	24/25	26/27	28	
D		29/30	31/32	33/34	35	
F		36/37	38/39	40/41	42	

Cells		COARSE/FINE					PERS > RES =
							4Ch
		R	G	B	A	Int	
A		1/2	3/4	5/6	7/8	9	
B		10/11	12/13	14/15	16/17	18	
C		19/20	21/22	23/24	25/26	27	
D		28/29	30/31	32/33	34/35	36	
E		37/38	39/40	41/42	43/44	45	
F		46/47	48/49	50/51	52/53	54	

Cells		COARSE/FINE				PERS > RES =
						3Ch
		R+A	G	B	Int	
A		1/2	3/4	5/6	7	
B		8/9	10/11	12/13	14	
C		15/16	17/18	19/20	21	
D		22/23	24/25	26/27	28	
E		29/30	31/32	33/34	35	
F		36/37	38/39	40/41	42	

Using master mode to drive other units

This unit can control any number of other Pixel Range fixtures via DMX links, without the need for a control desk.

- 1 Set this unit as **master** (*PERFS > DATA > MAST*) and ensure all others are set to **slave** (*PERFS > DATA > SLAVE*). Connect all fixtures via DMX daisy-chain.
- 2 Set slaves to *Mode > DM*. Set the master to either:
 - *Mode > EF M* and use *PRPG* to choose **effects**, or
 - *Mode > MANU* and use *MAN* to choose **colour mix**.
- 3 Use *Addr > DM* to set slave addresses (*the master unit's DMX address is ignored*):
 - **Effects:** 6 cells are output in groups of 4 DMX channels to give RGBA values per cell (24 channels in total). Set the address of each slave fixture according to which of the 6 cells you want them to appear within, or to begin with (for multi-cell fixtures): (*ADD 1* for cell 1, *ADD5* for cell 2, ... *ADD 1* for cell 6).
 - **Colour mix:** Set slaves to any addresses on 4 channel boundaries, e.g. *ADD 1*, *ADD5*, *ADD9*, ... *ADD 1*.

Troubleshooting

Fixture remains at blackout when illumination expected

- If the display panel is not showing any indication, even after a button press, check the input power and fuse.
- If live DMX is connected, the right hand decimal point on the display should flash - if not, check the DMX cable and the desk output.
- Check that the selected *Mode* matches the desk personality being used.
- The master intensity channel for the current mode may be set at zero. For *DM* or *LEVL* modes, check the setting of *PERFS > MINT*.
- Ensure that only one DMX device is set as master.
- Standalone chase effects: Effects programmed using *PRPG > C 1* and *C 2* but the fixture is not in *Mode > EF M* mode. Check also that *PRPG > LEVL* is not set at zero.
- Standalone RGB mixing: Colour values set within *MAN* section but the fixture is not in *Mode > MANU* mode.

Fuse access

The single fuse is located on the rear panel of the fixture.

To remove the fuse

Using a flatblade screwdriver, push in the fuse cap and then twist it anti-clockwise until it disengages from the holder.

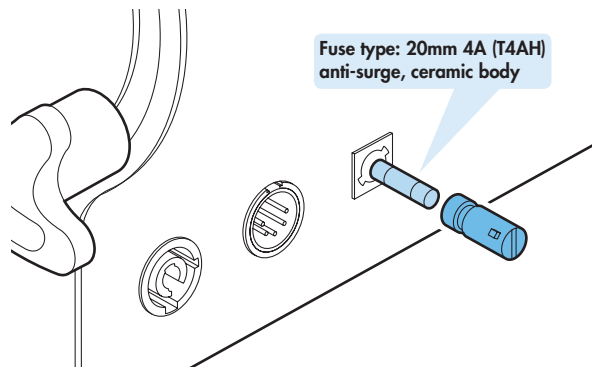

Documentation by Corporate Text & Design (www.ctxd.com)
Release 1.62b

Specifications

Dimensions

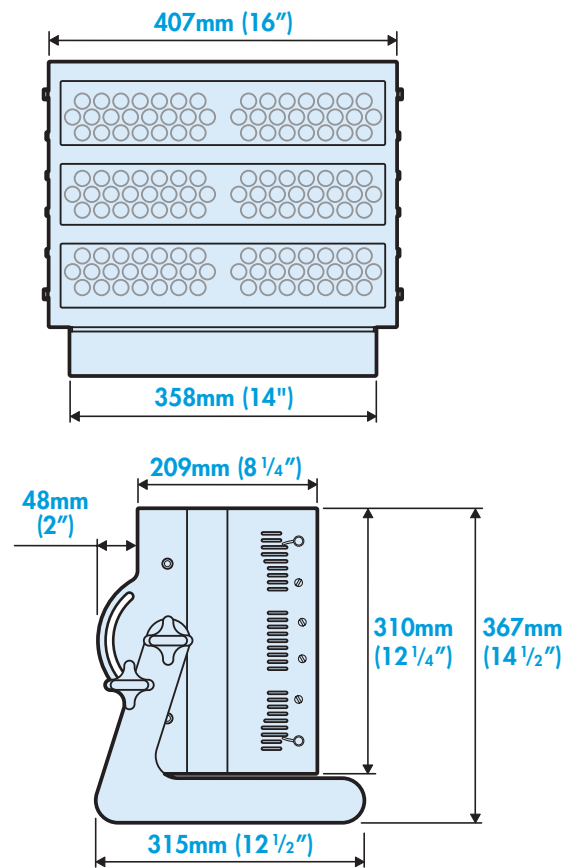

Weight

Fixture and yoke: 12.8Kg (28lbs)

Power

Input voltage:	90 to 264V AC, 47 to 63Hz autosensing	
Connectors:	Neutrik® PowerCon® (see first page for details)	
Power requirements:	@ 230V/50Hz	@ 115V/60Hz
Standby	10 watts	10 watts
Maximum (const.)	320 watts	320 watts
Start up (peak*)	<20 amps	<40 amps

* The peak value occurs only at first power up and lasts only for a period measured in microseconds. Adjustments may need to be made to supply circuit breakers when multiple fixtures are daisy-chained, causing them all to draw the peak simultaneously.

Approvals

Miscellaneous

Enclosure rating: IP20 (not protected against moisture ingress)
Control input: USITT DMX512 (input connector pin out below)

