

General set up

- 1 Mount the fixture in the required position using the supplied combi yoke or optional floor plate set (p/n: SSFLP).

Important

- When suspended off ground, always use safety wires rated to a minimum of 55kg (121lbs) at both ends of the fixture through the safety wire holes.
- Do not position the fixture close to fog machines. The fog oil mist will be drawn in by the cooling fans and will short out important components. The warranty will be void for all fixtures returned in such a condition.

- 2 Connect the power in and DMX in leads at the left end of the fixture.

- 3 Where multiple fixtures are to be daisy-chained, connect power out and DMX leads at the right end of the fixture.

Important

- When daisy-chaining fixtures, do not exceed a total load of 3kW in a single daisy chain (subject to supply and cabling restrictions). Each PixelLine 1044 fixture has a maximum power requirement of 140 watts.

- 4 When all fixtures are connected, apply power.

- 5 Use the control panel to access the internal menu and choose the appropriate operation mode and related settings (see over).

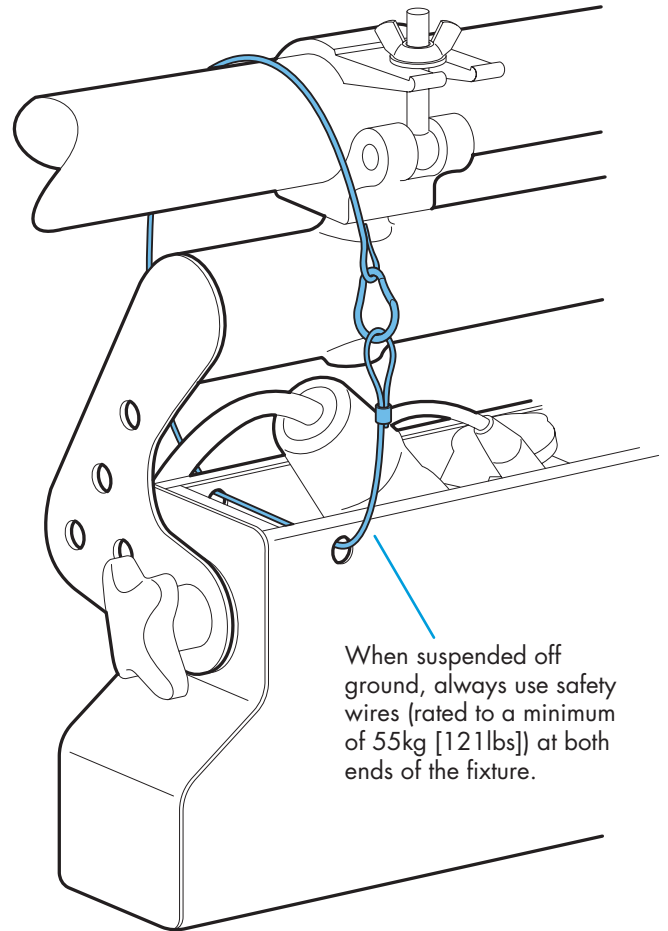

When suspended off ground, always use safety wires (rated to a minimum of 55kg [121lbs]) at both ends of the fixture.

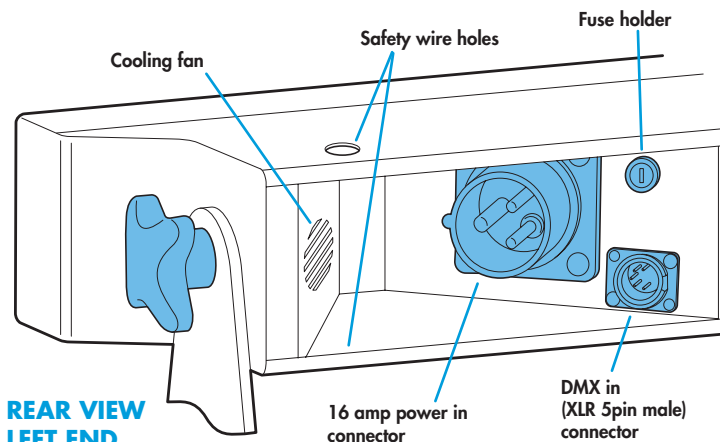

REAR VIEW
LEFT END

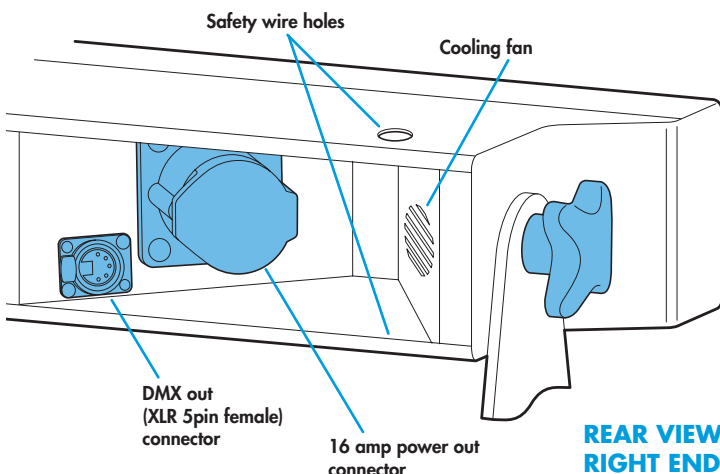

REAR VIEW
RIGHT END

Operation modes

The PixelLine 1044 provides a range of operation modes. These are selected using the **ModE** section of the control menu:

DMX Allows RGB control of all cells via DMX input. Using the **RES** (resolution) option you can determine the number of DMX channels required, from 54 channels down to just 3 (the cell sizes are adjusted accordingly). Internal chase effects are not available within this mode.

MA:1 Provides control of RGB mixing on all 18 cells and selection of the dual internal chase effects via DMX input. Requires 61 DMX channels.

MA:2 Provides control of RGB mixing (the whole fixture acts as a single cell) and selection of the dual internal chase effects via DMX input. Requires 10 DMX channels.

MANU Provides RGB colour mixing independently of any external control. Use the internal control menu (**MAN** section) to select the required colour values.

EF M Allows the display of the dual internal chase effects, independently of any external control. Use the internal control menu (**PRG** section) to select the required chase effects, speeds and cross fades.

EF d Superseded by (and operates in a similar manner to) **MA:2**. RGB mixing and chase effects cannot be used at the same time. Requires 10 DMX channels.

EX:1 Superseded by (and operates in a similar manner to) **MA:1**. RGB mixing and chase effects cannot be used at the same time. Requires 62 DMX channels.

PixelLine 1044 personalities are available for a variety of controllers. Please see www.pixelrange.com for details.

General notes

- Ensure that only one DMX device in the chain is set as master (e.g. the lighting desk). The fixture is usually set to slave mode **SLAVE**.
- If the fixture is used as a master, DMX transmission will only occur when the DMX address is displayed (e.g. **ADDR 1**, **ADDR 2**, etc).
- The four digit display can be set to fade out after 60 seconds, press **MENU** to resume. To alter this mode: **PER5 > DISP**.

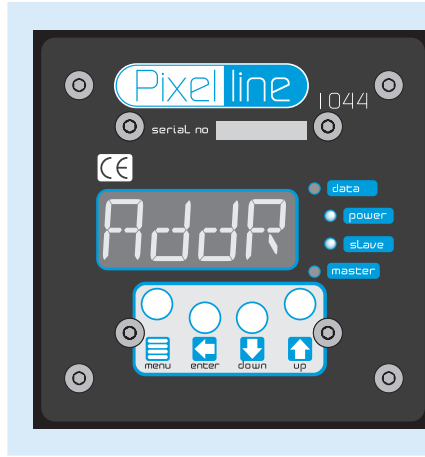

Using the control menu

- When not in the menu, the four digit display shows the current DMX address e.g. **ADDR 1**
- Press **MENU** to enter the menu. The four digit display will show **ADDR**.
- Use **DOWN** and **UP** to move between menu options (or to change a value within an option).
- Press **ENTER** to enter an option (or to fix a changed value within an option and return to the previous option level). *Note: If you do not press **ENTER** to fix a value, operation will revert to the previously set mode at the next power on.*
- Press **MENU** to exit from a menu option (and eventually exit the menu completely).

Chase effects

This section describes each of the 31 internal chase effects that are selectable either via the control menu (**PRPG > C1/C2 > EFEC**) or using DMX values sent from an external source. To use the internal effects, set the **MODE** option either to **EF M** (to control effects via the menu) or **EF d, E:B 1, MA: 1** or **MA: 2** (to control effects externally via DMX).

DMX value	EFEC value	Chase effect description
0-7	00	Off
8-15	01	Rainbow chase forward - 6 cell split
16-23	02	Rainbow chase reverse - 6 cell split
24-31	03	White single cell chase forward
32-39	04	White single cell chase reverse
40-47	05	Double bouncing cells - centre to edge
48-55	06	50/50 duty cycle strobe white
56-63	07	50/50 duty cycle strobe red
64-71	08	50/50 duty cycle strobe blue
72-79	09	50/50 duty cycle strobe yellow
80-87	10	50/50 duty cycle strobe green
88-95	11	Pulse strobe white
96-103	12	Pulse strobe blue
104-111	13	Pulse strobe rainbow
112-119	14	Pulse strobe red/green/blue
120-127	15	Primary/secondary chase
128-135	16	Rainbow chase
136-143	17	Yellow/blue chase
144-151	18	Rainbow chase - 2 cell split
152-159	19	Yellow/blue alternate cell chase
160-167	20	Red/blue alternate cell chase
168-175	21	Red/green chase
176-183	22	Rainbow chase - 6 cell split
184-191	23	Rainbow chase - 3 cell split
192-199	24	Red/green/blue chase - 3 cell split
200-207	25	Static orange
208-215	26	Static yellow
216-223	27	Static light blue
224-231	28	Static purple
232-239	29	Static red
240-247	30	Static green
248-255	31	Static blue

DMX channel and cell layouts

This section shows the different ways, when using **dm: 1** mode, that the 18 cells can be mapped to varying numbers of DMX channels using the **PER5 > RES** option.

The first channel of the fixture occurs at the DMX address selected using **ADDR** and successive channels for the fixture follow from there.

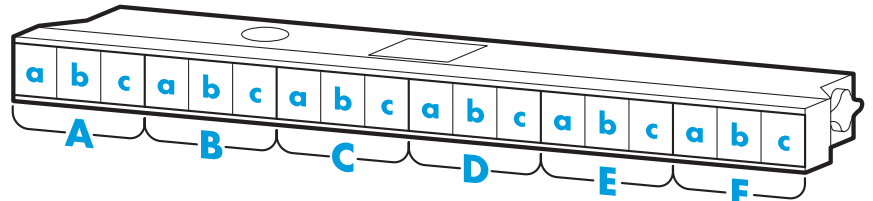

Cells	54CH	27CH	18CH	9CH	6CH	3CH
	R G B	R G B	R G B	R G B	R G B	R G B
Aa	1 2 3] 1 2 3] 1 2 3] 1 2 3] 1 2 3] 1 2 3
Ab	4 5 6					
Ac	7 8 9					
Ba	10 11 12] 4 5 6] 4 5 6] 1 2 3] 1 2 3] 1 2 3
Bb	13 14 15					
Bc	16 17 18					
Ca	19 20 21] 10 11 12] 7 8 9] 4 5 6] 4 5 6] 1 2 3
Cb	22 23 24					
Cc	25 26 27					
Da	28 29 30] 13 14 15] 13 14 15] 7 8 9] 4 5 6] 1 2 3
Db	31 32 33					
Dc	34 35 36					
Ea	37 38 39] 19 20 21] 16 17 18] 7 8 9] 4 5 6] 1 2 3
Eb	40 41 42					
Ec	43 44 45					
Fa	46 47 48] 22 23 24] 25 26 27] 7 8 9] 4 5 6] 1 2 3
Fb	49 50 51					
Fc	52 53 54					
Master int*	55	28	19	10	7	4

Modes **E:B 1** and **MA: 1** use a 54 channel layout. Modes **MA: 2** and **EF d** use a 3 channel layout (Mode **EF d** uses channels 8, 9 and 10 for RGB control).

Chase effects and master intensity channel layouts

The table below shows how the chase effects and master intensity controls are mapped to DMX channels for each mode. Mode **dm: 1** does not use chase effects. The first channel of the fixture occurs at the DMX address selected using **ADDR** and successive channels for the fixture follow from there.

Control	MA: 1	MA: 2	EF d	E:B 1
C 1 Effect	Ch55	Ch4	Ch1	Ch56
C 1 Speed	Ch56	Ch5	Ch2	Ch57
C 1 Xfade	Ch57	Ch6	Ch3	Ch58
C 2 Effect	Ch58	Ch7	Ch4	Ch59
C 2 Speed	Ch59	Ch8	Ch5	Ch60
C 2 Xfade	Ch60	Ch9	Ch6	Ch61
RGB master intensity	None	None	None	Ch55
Effects master intensity	None	None	None	Ch62
Combined master intensity	Ch61	Ch10	Ch7	None

* **dm: 1** mode only, when **PER5 > MINT** is set to **dm**.

Control menu contents

Addr → DMX → 001

Sets the base DMX address from which the control channels will begin.

Info → VER → CPU → 1 07

Shows the main processor software revision. No changes are possible within this option.

DISP → 1 00

Shows the display controller software revision. No changes are possible within this option.

Prog → C1 → EFEC → 00

Selects the primary internal chase effect. See *Chase effects* for descriptions. Select **Mode** > **EF M** to show the selected chase.

XFAD → 000

Selects the cross fade speed between the steps of the selected C1 chase effect.

SPEd → 000

Selects the speed of the selected C1 chase effect.

LEVl → 255

Selects the master intensity level of chase effects C1 and C2.

C2 → EFEC → 00

Selects the secondary internal chase effect. See *Chase effects* for descriptions. Select **Mode** > **EF M** to show the selected chase.

XFAD → 000

Selects the cross fade speed between the steps of the selected C2 chase effect.

SPEd → 000

Selects the speed of the selected C2 chase effect.

MAN → RED → 255

Sets the red intensity for all cells. Select **Mode** > **MANU** (manual) to show the result.

GRN → 255

Sets the green intensity for all cells. Select **Mode** > **MANU** (manual) to show the result.

BLUE → 255

Sets the blue intensity for all cells. Select **Mode** > **MANU** (manual) to show the result.

PERS → RES → 54ch

DMX mode only. Selects number of DMX channels required to control RGB in all cells. Options range from 54 through 27, 18, 9, 6 and 3. Cell sizes are adjusted to suit.

DATA → SLAV

Determines whether this fixture will act as a master controlling others. When controlled via DMX this fixture must be set to **SLAV**.

MINT → OFF

DMX and **E:B 1** modes only. When set **ON** this enables the master intensity channel (ch55 for **E:B 1**, variable for **DMX**). This option must be set **ON** for **E:B 1** mode.

RSET → OFF

When set **ON**, this option scrolls through the primary colours at power on to demonstrate correct operation.

dINT → 15

Determines the intensity of the four digit control panel display and blue status indicators. Values range from 0 (dimpest) to 15 (brightest).

DISP → ON

When set to **OFF**, the control panel display will blank out 60 seconds after the menu is exited. The blue status indicators will remain active.

Mode → DMX

RGB control for cells using variable DMX channels determined by **PERS** > **RES** setting. **MINT** set to **ON** provides master intensity. No chase effects are selectable.

MANU

Displays the resulting RGB levels (of all cells combined) that are set via the **MAN** section of the internal menu. External DMX control is not possible in this mode.

EF d

Ch1 to 3: C1 Effect, Speed & Xfade, Ch4 to 6: C2 Effect, Speed & Xfade, Ch7: Master intensity, Ch8-10: RGB.

EF M

Displays the chase effect(s) determined within the **PRoG** section. External DMX control is not possible in this mode.

E×B 1

DMX Ch1 to 54: RGB for indiv. cells, Ch55: RGB mast intensity, Ch56 to 58: C1 Effect, Speed & Xfade, Ch59 to 61: C2 Effect, Speed & Xfade, Ch62: Effects intensity.

MAX 1

DMX Ch1 to 54: RGB for individual cells, Ch55 to 57: C1 Effect, Speed & Xfade, Ch58 to 60: C2 Effect, Speed & Xfade, Ch61: Master intensity.

MAX 2

DMX Ch1 to 3: RGB, Ch4 to 6: C1 Effect, Speed & Xfade, Ch7 to 9: C2 Effect, Speed & Xfade, Ch10: Master intensity.

Using master mode to drive other units

This unit can control any number of other Pixel Range fixtures via DMX links, without the need for a control desk.

- 1 Set this unit as **master** (*PERFS > DATA > MAST*) and ensure all others are set to **slave** (*PERFS > DATA > SLAVE*). Connect all fixtures via DMX daisy-chain.
- 2 Set each slave to *ModE > dM*.
- 3 Set each slave DMX address (using *AddrP > dM*) according to the following:

18 cells are output in groups of 3 DMX channels to give RGB values per cell (54 channels in total). Set the address of each slave fixture according to which of the 18 cells you want them to appear within, or to begin with (for multi-cell fixtures): *RGB 1* for cell 1, *RGB 4* for cell 2, ... *RGB 2* for cell 18). Set RGBA slave fixtures to 3 channel mode (using *PERFS > RES > 3Ch*).

- 4 Set the master to *ModE > EF M* (the master unit's DMX address is ignored). On the master, choose the required effects to display and send to the slave fixtures using *PRoB > C 1* and *C 2*.

Troubleshooting

Fixture remains at blackout when illumination expected

- The **power** indicator should be lit - if not, check the input power and fuse (see below).
- If live DMX is connected, the **data** indicator should be lit - if not, check the DMX cable and the desk output.
- Check that the selected *ModE* matches the desk personality being used.
- The master intensity channel for the current mode may be set at zero. For *RGB 1* and *dM* modes, check the setting of *PERFS > MINT*. For *RGB 1* mode, *MINT* must be set *off*.
- Ensure that only one DMX device in the chain is set as master.
- Standalone chase effects: Effects programmed using *PRoB > C 1* and *C 2* but the fixture is not in *ModE > EF M* mode. Check also that *PRoB > LEVEL* is not set at zero.
- Standalone RGB mixing: Colour values set within *MANU* section but the fixture is not in *ModE > MANU* mode.

Unexpected cell illumination occurring

- When using *dM* mode: Check the setting of *PERFS > RES*. See the section "DMX channel and cell layouts" on page 2 for an explanation of the various resolution modes.

Fuse access

The single fuse is located next to the power and DMX input connectors. Use a small flat blade screw driver to twist the fuse holder anticlockwise until the carrier can be extracted to reveal the fuse.

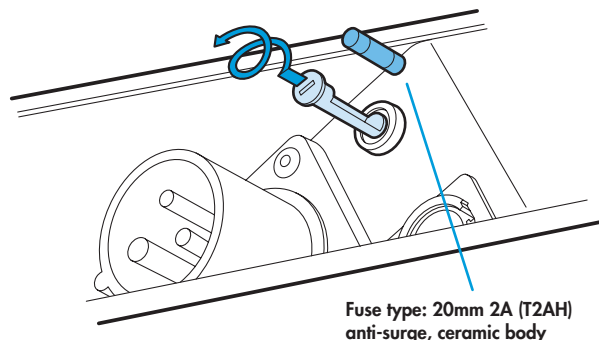

Specifications

Dimensions

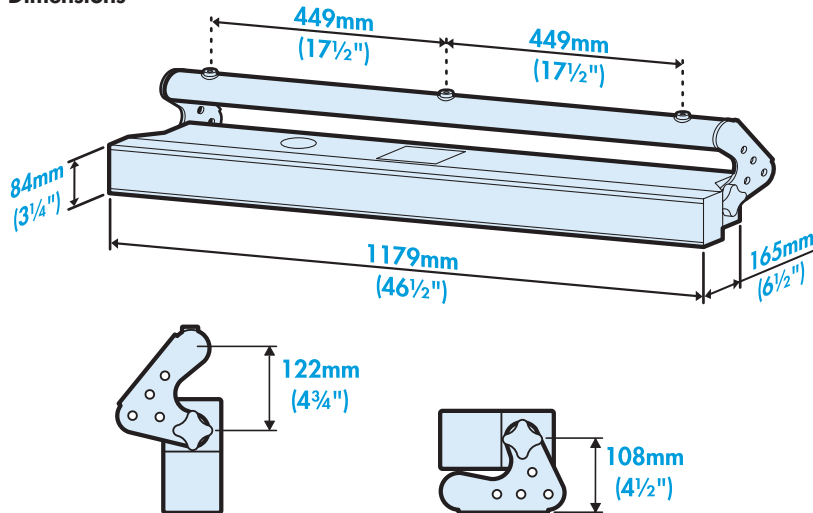

Weight

Fixture alone:	11 kg (24 lbs)
With combi yoke:	12.2 kg (26.9 lbs)

Power

Input voltage:	90 to 264V AC, 47 to 63Hz autosensing	
Earth leakage:	0.22mA	
Connectors:	16 amp CEE Form 2Pole+Earth (input & output)	
Power requirements:	@ 230V/50Hz	@ 115V/60Hz
Standby	20 watts	20 watts
Maximum (const.)	140 watts	140 watts
Start up (peak*)	32 amps	16 amps

* The peak value occurs only at first power up and lasts only for a period measured in microseconds. Adjustments may need to be made to supply circuit breakers when multiple fixtures are daisy-chained, causing them all to draw the peak simultaneously.

Approvals



Miscellaneous

Enclosure rating:	IP20 (not protected against moisture ingress)
Control input:	USITT DMX512 (input connector pin out below)

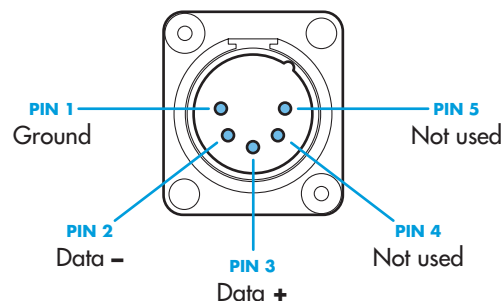

Documentation by Corporate Text & Design (www.ctxd.com)
Release 1.07b (original panel)