

General set up

- 1 Mount the fixture in the required position using the supplied combi yoke or optional floor plate set (p/n: SSFLP).

Important

- When suspended off ground, always use safety wires rated to a minimum of 53kg (117lbs) at both ends of the fixture through the safety wire holes.
- Do not position the fixture close to fog machines. The fog oil mist will be drawn in by the cooling fans and will short out important components. The warranty will be void for all fixtures returned in such a condition.

- 2 Connect the power in and DMX in connectors at the left end of the fixture.

- 3 Where multiple fixtures are to be daisy-chained, connect power out and DMX cables at the right end of the fixture.

Important

- When daisy-chaining fixtures, do not exceed a total load of 3kW in a single daisy chain (subject to supply and cabling restrictions). Each PixelLine 110 fixture has a maximum power requirement of 300 watts.

- 4 When all fixtures are connected, apply power.

- 5 Use the control panel to access the internal menu and choose the appropriate operation mode and related settings (see over).

- To optionally clear all previous settings: At the rear panel, press the middle two buttons (▶ and ▼) while the DMX address is displayed (e.g. *ADD 1*, *ADD 2*, etc). The four digit display will show *FAC T* then *SET* to indicate that the fixture has been returned to its default condition.

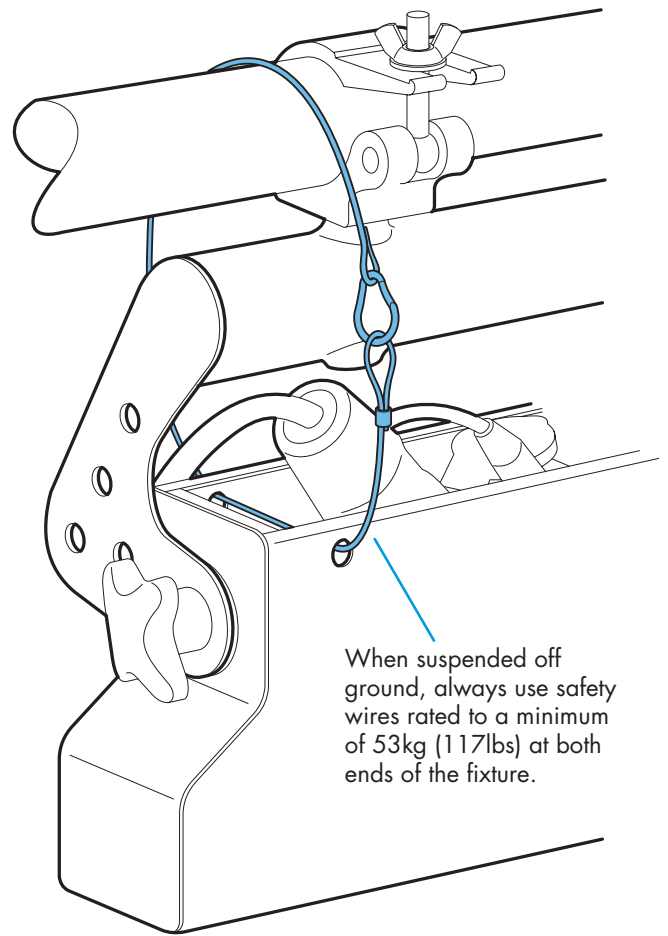
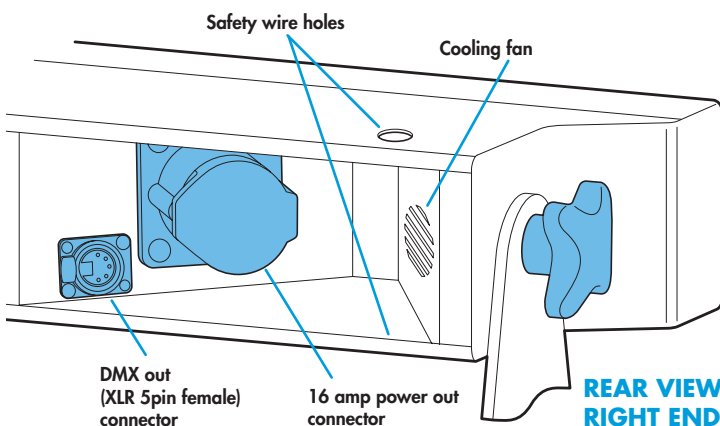
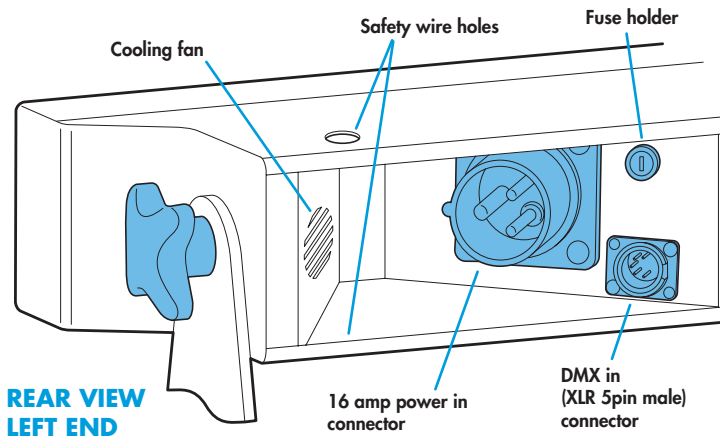

Operation modes

The PixelLine 110 provides a range of operation modes. These are selected using the *ModE* section of the control menu:

DMX Allows RGB(A) control of all cells via DMX input. Using the *RES* (resolution) option you can determine the number of DMX channels required, from 20 channels down to just 3 (the cell sizes and colour permutations are adjusted accordingly). Internal chase effects are not available within this mode.

MANU Provides RGBA colour mixing independently of any external control. Use the internal control menu (*MAN* section) to select the required colour values.

EF M Allows the display of the dual internal chase effects, independently of any external control. Use the internal control menu (*PRG* section) to select the required chase effects, speeds and cross fades.

20+E Provides control of RGBA mixing on all 5 cells and selection of the dual internal chase effects via DMX input. Requires 27 DMX channels.

4+E Provides control of RGBA mixing (the whole fixture acts as a single cell) and selection of the dual internal chase effects via DMX input. Requires 11 DMX channels.

16bT Allows RGB(A) control via DMX input, using two 8bit channels per colour. The *RES* and *MINT* options determine how many channels are required. Internal chase effects are not available within this mode.

PixelLine 110 personalities are available for a variety of controllers. Please see www.pixelrange.com for details.

General notes

- Ensure that only one DMX device in the chain is set as master (e.g. the lighting desk). This fixture is usually set to slave mode.
- This fixture is shipped with the DMX address set to 001.
- The four digit display can be set to switch off when not in use. To restore, press **⏏**. To alter this mode use: **PER5 > dISP**.

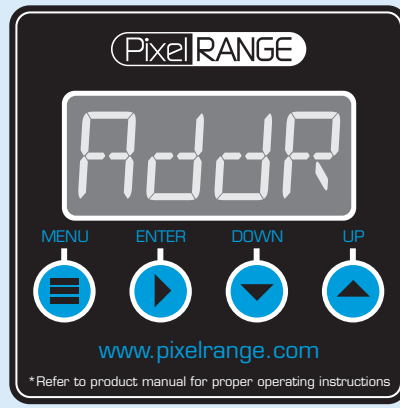

Using the menu

- When not in the menu, the four digit display shows the current DMX address e.g. **0001**. Some of the display's decimal points are used to indicate status (see below).
- Press **⏏** to enter the menu. The four digit display will show **Ad d R**.
- Use **⬇** and **⬆** to move between menu options (or to change a value within an option).
- Press **⬆** to enter an option (or to fix a changed value within an option and return to the previous option level). *Note: If you do not press **⬆** to fix a value, operation will revert to the previously set mode at the next power on.*
- Press **⏏** to exit from a menu option (and eventually exit the menu completely).

Chase effects

This section describes each of the 31 internal chase effects that are selectable either via the control menu (**PER5 > C 1/C2 > EFEC**) or using DMX values sent from an external source. To use the internal effects, set the **ModE** option either to **EF M** (to control effects via the menu) or **4+E** or **20+E** (to control effects externally via DMX).

DMX value	EFEC value	Chase effect description
0-7	00	Off
8-15	01	Rainbow chase forward
16-23	02	Rainbow chase reverse
24-31	03	White single cell chase forward
32-39	04	White single cell chase reverse
40-47	05	Double bouncing white cells
48-55	06	50/50 duty cycle strobe white
56-63	07	50/50 duty cycle strobe red
64-71	08	50/50 duty cycle strobe blue
72-79	09	50/50 duty cycle strobe yellow
80-87	10	50/50 duty cycle strobe green
88-95	11	Pulse strobe white
96-103	12	Pulse strobe blue
104-111	13	Pulse strobe rainbow
112-119	14	Pulse strobe red/green/blue
120-127	15	Primary/secondary strobe
128-135	16	Rainbow strobe
136-143	17	Yellow/blue strobe
144-151	18	Rainbow strobe
152-159	19	Yellow/blue alternate cell chase
160-167	20	Red/blue alternate cell chase
168-175	21	Red/green alternate cell chase
176-183	22	Red/green/blue 2/3 cell split
184-191	23	Green/purple strobe
192-199	24	Red/green/blue strobe
200-207	25	Static orange
208-215	26	Static yellow
216-223	27	Static light blue
224-231	28	Static lilac
232-239	29	Static red
240-247	30	Static green
248-255	31	Static blue

Master/slave/data indication

The right hand decimal point (data dot) of the display is used to indicate the master/slave settings and also the presence of a DMX input signal, as shown below:



Data dot ON	Master mode
Data dot FLASHING	Slave mode (DMX data input present)
Data dot OFF	Slave mode (no DMX data present)

Notes:

- Ensure that only one DMX device in the chain is set as master (e.g. the desk).
- Use **PER5 > dATR** to change between master and slave modes.
- When set to master mode, the fixture will scroll **MASTER** in place of a DMX address (when not within the menu).
- If the display has been set to auto off (**dISP > Roff**), the data dot will remain active but at a lower brightness.

Channel layouts within operation modes

See page 4

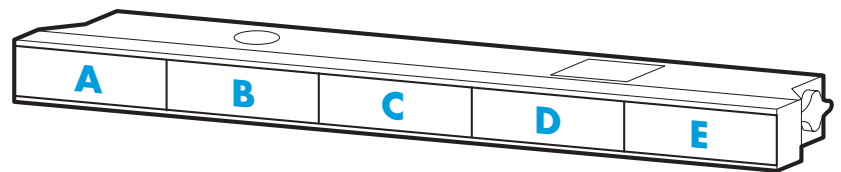

Dimming options (PER5 > dIMR)

You have a choice of dimmer two curve control options:

FINE is the standard setting and is fully compatible with the dimming curves of previous Pixel Range fixtures.

TUNG Alters the dimming response to closely emulate the very smooth action of standard tungsten bulbs. The **TUNG** setting can be used with all operation modes. However, within the effects modes (**EF M**, **20+E** and **4+E**), the **TUNG** setting will only be effective if the **C 1/C2 SPED** option is less than 25 **and** the **C 1/C2 *FRd** option is less than 127.

Control menu contents

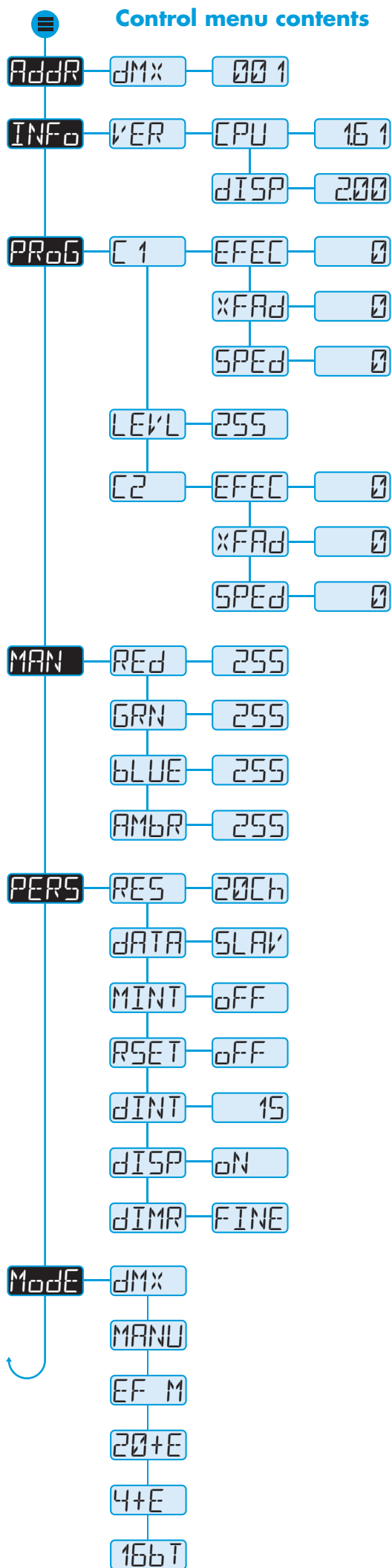

Sets the base DMX address from which the control channels will begin.

Shows the main processor software revision. No changes are possible within this option.

Shows the display controller software revision. No changes are possible within this option.

Selects the primary internal chase effect. See *Chase effects* for descriptions. Select *ModE > EF M* to show the selected chase.

Selects the cross fade speed between the steps of the selected *C 1* chase effect.

Selects the speed of the selected *C 1* chase effect.

Selects the master intensity level of chase effects *C 1* and *C 2*.

Selects the secondary internal chase effect. See *Chase effects* for descriptions. Select *ModE > EF M* to show the selected chase.

Selects the cross fade speed between the steps of the selected *C 2* chase effect.

Selects the speed of the selected *C 2* chase effect.

Sets the red intensity for all cells. Select *ModE > MANU* (manual) to show the result.

Sets the green intensity for all cells. Select *ModE > MANU* (manual) to show the result.

Sets the blue intensity for all cells. Select *ModE > MANU* (manual) to show the result.

Sets the amber intensity for all cells. Select *ModE > MANU* (manual) to show the result.

dMX mode only. Selects number of DMX channels required to control RGB in all cells. Options range from 20 through 15, 4 and 3. Cell sizes & colours are adjusted to suit.

Determines whether this fixture will act as a master controlling others. When controlled via DMX this fixture must be set to *SLAV*.

dMX mode only. When set *ON*, this enables a master intensity at the channel that immediately follows the number set within the *PERS > RES* option.

When set *ON*, this option scrolls through the primary colours at power on to demonstrate correct operation.

Determines the intensity of the four digit control panel display and blue status indicators. Values range from 0 (dimkest) to 15 (brightest).

When set to *OFF*, the control panel display will blank out 60 seconds after the menu is exited. The blue status indicators will remain active.

Allows you to choose dimming curve & response rate. *FINE* is compatible with previous Pixel Range fixtures. *TUNG* produces very smooth responses.

RGBA control for cells using variable DMX channels determined by *PERS > RES* setting. *MINT* set *ON* provides master intensity. No chase effects are selectable.

Displays the resulting RGBA levels (of all cells combined) that are set via the *MAN* section of the internal menu. External DMX control is not possible in this mode.

Displays the chase effect(s) determined within the *PROG* section. External DMX control is not possible in this mode.

DMX Ch 1 to 20: RGBA for indiv. cells, Ch21 to 23: C1 Effect, Speed & Xfade, Ch24 to 26: C2 Effect, Speed & Xfade, Ch27: Master intensity.

DMX Ch 1 to 4: RGBA for all cells, Ch5 to 7: C1 Effect, Speed & Xfade, Ch8 to 10: C2 Effect, Speed & Xfade, Ch11: Master intensity.

16bit RGB(A) control using 2x the number of DMX channels determined by *PERS > RES*. *PERS > MINT* set to *ON* provides a master intensity. No chase effects are selectable.

Channel layouts within operation modes

These tables show how colour mixing, chase effects and master intensity controls are mapped to DMX channels for each mode that uses an external input. The **dMx** and **16bT** modes do not use chase effects. In all modes, the first channel of the fixture occurs at the DMX address selected using **Addr** and successive channels for the fixture follow from there.

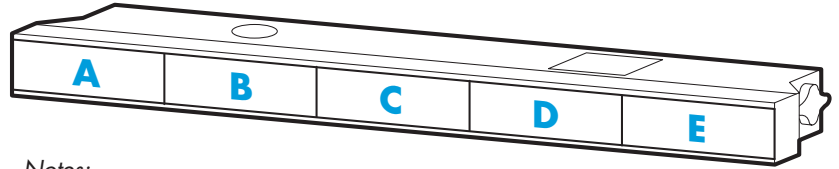

Notes:

The **PERS > RES** option determines the number of channels to use in **dMx** and **16bT** modes (**16bT** uses twice the number of channels setup within **RES**).

For **dMx** and **16bT** modes, the **PERS > MINT** option determines whether a master intensity channels should be used.

Mode = dMx

(* Master intensity only when **PERS > MINT** is set to **ON**)

PER5 > RES = 20Ch		PER5 > RES = 15Ch		PER5 > RES = 4Ch		PER5 > RES = 3Ch	
Cells	R G B A	Cells	R+A G B	Cells	R G B A	Cells	R+A G B
A	1 2 3 4	A	1 2 3	A	1 2 3 4	A	1 2 3
B	5 6 7 8	B	4 5 6	B			
C	9 10 11 12	C	7 8 9	C			
D	13 14 15 16	D	10 11 12	D			
E	17 18 19 20	E	13 14 15	E		E	
Master intensity* 21		Master intensity* 16		Master intensity* 5		Master intensity* 4	

Mode = 16bT (16 bit)

(* Master intensity only when **PERS > MINT** is set to **ON**)

In each pair of channels for a colour, the first channel provides the high (coarse) 8 bits while the second gives the low (fine) 8 bits

COARSE/FINE		PER5 > RES = 20Ch		PER5 > RES = 15Ch		PER5 > RES = 4Ch		PER5 > RES = 3Ch	
Cells	R G B A	Cells	R+A G B	Cells	R G B A	Cells	R+A G B	Cells	R+A G B
A	1/2 3/4 5/6 7/8	A	1/2 3/4 5/6	A	1/2 3/4 5/6 7/8	A	1/2 3/4 5/6		
B	9/10 11/12 13/14 15/16	B	7/8 9/10 11/12	B					
C	17/18 19/20 21/22 23/24	C	13/14 15/16 17/18	C					
D	25/26 27/28 29/30 31/32	D	19/20 21/22 23/24	D					
E	33/34 35/36 37/38 39/40	E	25/26 27/28 29/30	E		E			
Master intensity* 41		Master intensity* 31		Master intensity* 9		Master intensity* 7			

Mode = 20+E

This mode provides a combination of colour mixing and internal effects under the control of a DMX input.

See page 2 (Chase effects) for details of values for C1 and C2 effect channels.

Cells	R G B A
A	1 2 3 4
B	5 6 7 8
C	9 10 11 12
D	13 14 15 16
E	17 18 19 20
C1 effect	21
C1 speed	22
C1 xfade	23
C2 effect	24
C2 speed	25
C2 xfade	26
Master Int.	27

Mode = 4+E

This mode provides a combination of colour mixing and internal effects under the control of a DMX input.

See page 2 (Chase effects) for details of values for C1 and C2 effect channels.

Cells	R G B A
A	1 2 3 4
B	
C	
D	
E	
C1 effect	5
C1 speed	6
C1 xfade	7
C2 effect	8
C2 speed	9
C2 xfade	10
Master Int.	11

Using master mode to drive other units

This unit can control any number of other Pixel Range fixtures via DMX links, without the need for a control desk.

- 1 Set this unit as **master** (**PERFS > DATA > MAST**) and ensure all others are set to **slave** (**PERFS > DATA > SLAVE**). Connect all fixtures via DMX daisy-chain.
- 2 Set slaves to **ModE > dM::**. Set the master to either:
 - **ModE > EF M** and use **PRoG** to choose **effects**, or
 - **ModE > MANU** and use **MAN** to choose **colour mix**.
- 3 Use **AddrP > dM::** to set slave addresses (*the master unit's DMX address is ignored*):
 - **Effects**: 5 cells are output in groups of 4 DMX channels to give RGBA values per cell (20 channels in total). Set the address of each slave fixture according to which of the 5 cells you want them to appear within, or to begin with (for multi-cell fixtures): (**ADD 1** for cell 1, **ADD5** for cell 2, **ADD9** for cell 3, **AD 13** for cell 4, **AD 17** for cell 5).
 - **Colour mix**: Set slaves to any addresses on 4 channel boundaries: **ADD 1**, **ADD5**, **ADD9**, **AD 13**, **AD 17**.

Troubleshooting

Fixture remains at blackout when illumination expected

- If the display panel is not showing any indication, even after a button press, check the input power and fuse.
- If live DMX is connected, the right hand decimal point on the display should flash - if not, check the DMX cable and the desk output.
- Check that the selected **ModE** matches the desk personality being used.
- The master intensity channel for the current mode may be set at zero. For **dM::** or **LEBT** modes, check the setting of **PERFS > MINT**.
- Ensure that only one DMX device is set as master.
- Standalone chase effects: Effects programmed using **PRoG > C 1** and **C 2** but the fixture is not in **ModE > EF M** mode. Check also that **PRoG > LEVL** is not set at zero.
- Standalone RGBA mixing: Colour values set within **MAN** section but the fixture is not in **ModE > MANU** mode.

Fuse access

The single fuse is located next to the power and DMX input connectors. Use a small flat blade screw driver to twist the fuse holder anticlockwise until the carrier can be extracted to reveal the fuse.

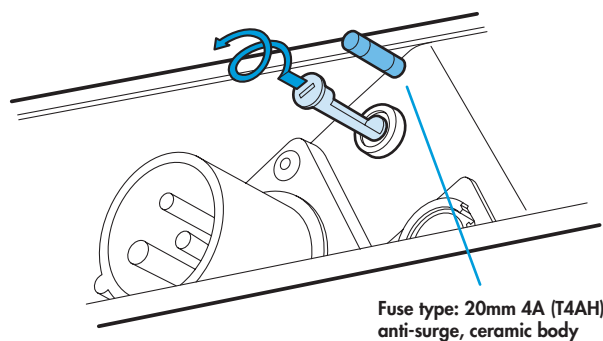

Specifications

Dimensions

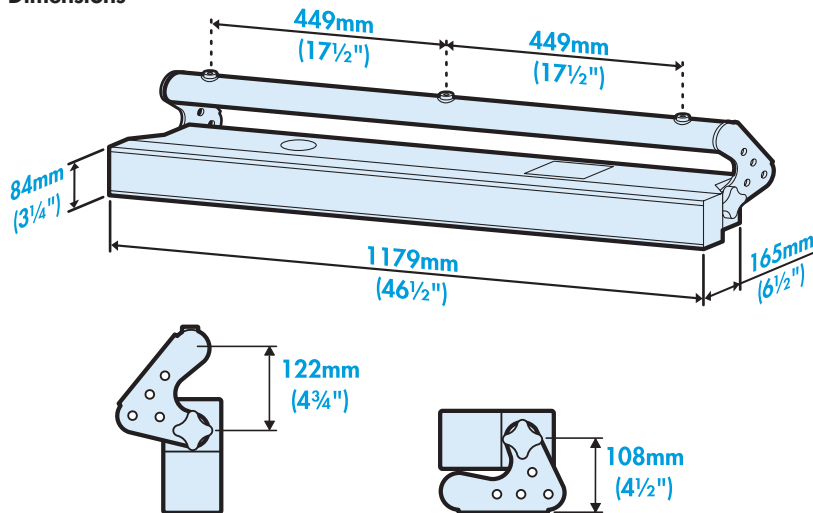

Weight

Fixture alone:	10.5kg (23 lbs)
With combi yoke:	11.7kg (25.8 lbs)

Power

Input voltage:	90 to 264V AC, 47 to 63Hz autosensing	
Earth leakage:	1.61mA	
Connectors:	16 amp CEE Form 2Pole+Earth (input & output)	
Power requirements:	@ 230V/50Hz	@ 115V/60Hz
Standby	20 watts	20 watts
Maximum (const.)	300 watts	300 watts
Start up (peak*)	128 amps	64 amps

* The peak value occurs only at first power up and lasts only for a period measured in microseconds. Adjustments may need to be made to supply circuit breakers when multiple fixtures are daisy-chained, causing them all to draw the peak simultaneously.

Approvals



Miscellaneous

Enclosure rating:	IP20 (not protected against moisture ingress)
Control input:	USITT DMX512 (input connector pin out below)

